

Survey Order Sheet

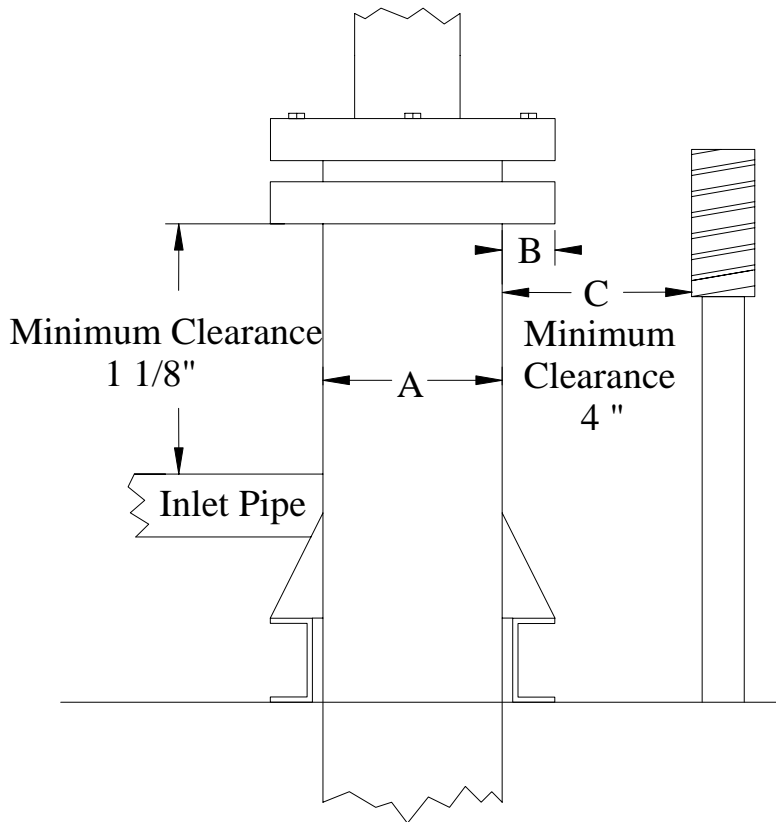

Order Your Drip Ring In Three Easy Steps !

Step 1

Establish the 'A' dimension by measuring the diameter of the cylinder where the ring will be installed.

'A' = _____ inches

Step 2

Confirm that the maximum overhang (shown as 'B') of the packing head is 3 3/4" or less.

Step 3

Confirm that the minimum side clearance (shown as 'C') measures is 4" or more.

DIAMETER	CIRCUMFERENCE	MODEL
5 3/4" – 7"	18" – 22"	EDR – 1
7" – 8 1/2"	22" – 26"	EDR – 2
8 1/2" – 10"	26" – 31"	EDR – 3
10" – 12"	31" – 37 1/2"	EDR – 4
12" – 16"	37 1/2" – 50"	EDR – 5
3-7/8	Dover Inverted	EDR – IVO

Elator Enterprises Inc.

240 Rolson Street, Oshawa, Ontario, Canada L1G 7Y9

Toll Free: 877 435 1105, Main Line: 905 435 1105, Cell: 905 431 6333, Fax: 905 435 1165

www.elator.net